

SPECIFICATIONS:

NOMINALLY RATED AT 2400GPD (9.08M3D)
 AT 1000 TDS NaCl / 25 CELSIUS (77F) / 135 PSI
 ALL STAINLESS STEEL PLUMBING
 POWDER COATED ALUMINUM FRAME
 SYSTEM-230/208V 60Hz, 6.4/7.1FLA, SF 1.25
 NOMINAL OPERATING PRESSURE 135 PSI
 MAX OPERATING PRESSURE 150 PSI
 AUTO FLUSH STANDARD
 DUAL PROBE TDS MONITOR STANDARD
 INLET 1" FPT, PERMEATE 1/2" FPT, DRAIN 3/4" FPT
 5 MICRON PRE-FILTER W/PRE & POST PRESSURE GAUGES
 CONFORMS TO UL STD. 979
 CERTIFIED TO CSA STD C22.2 No. 68

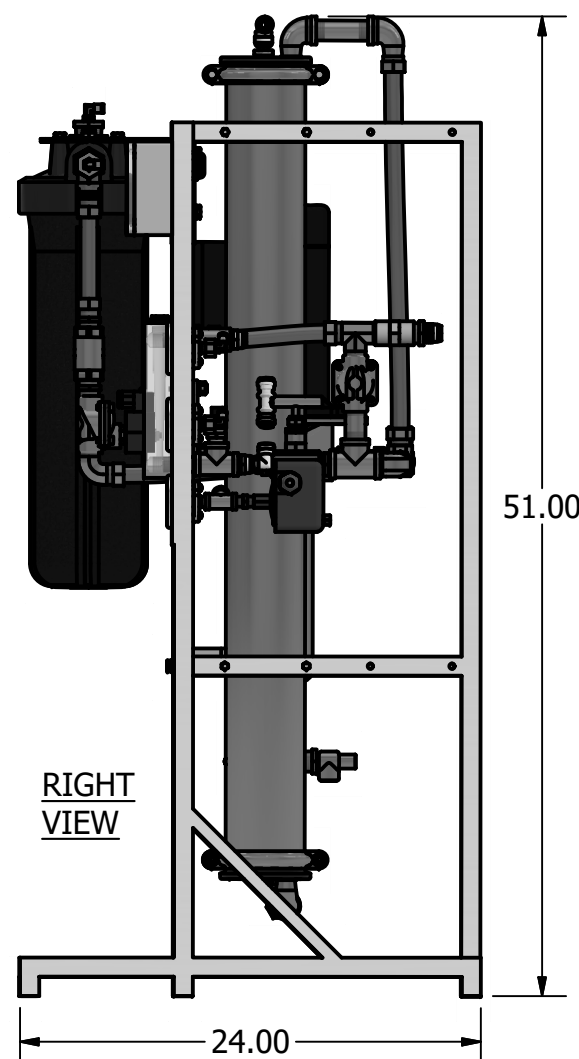
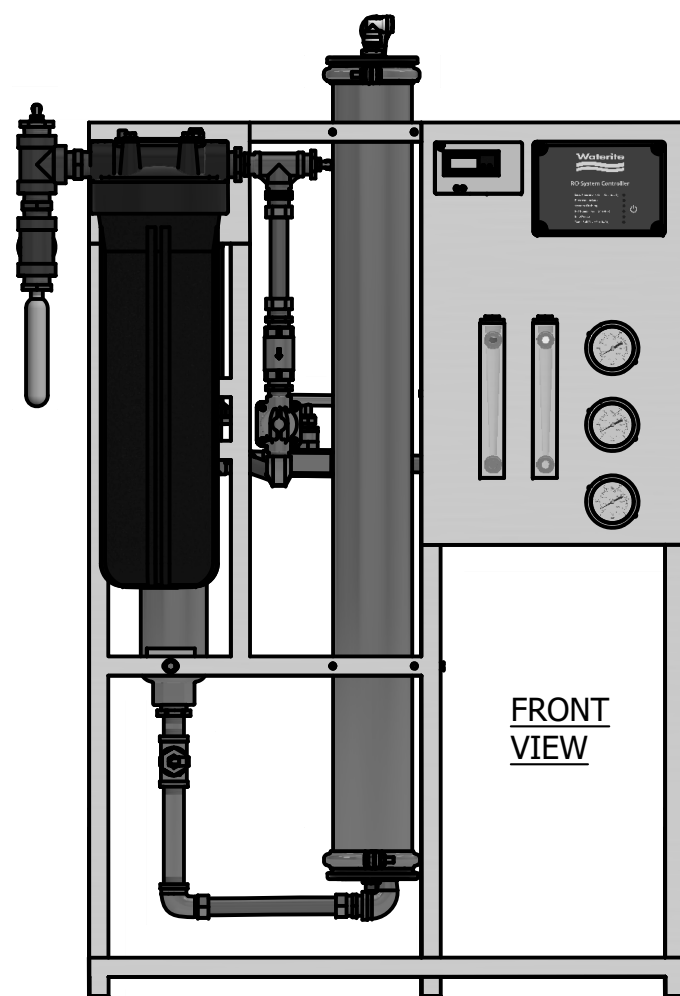
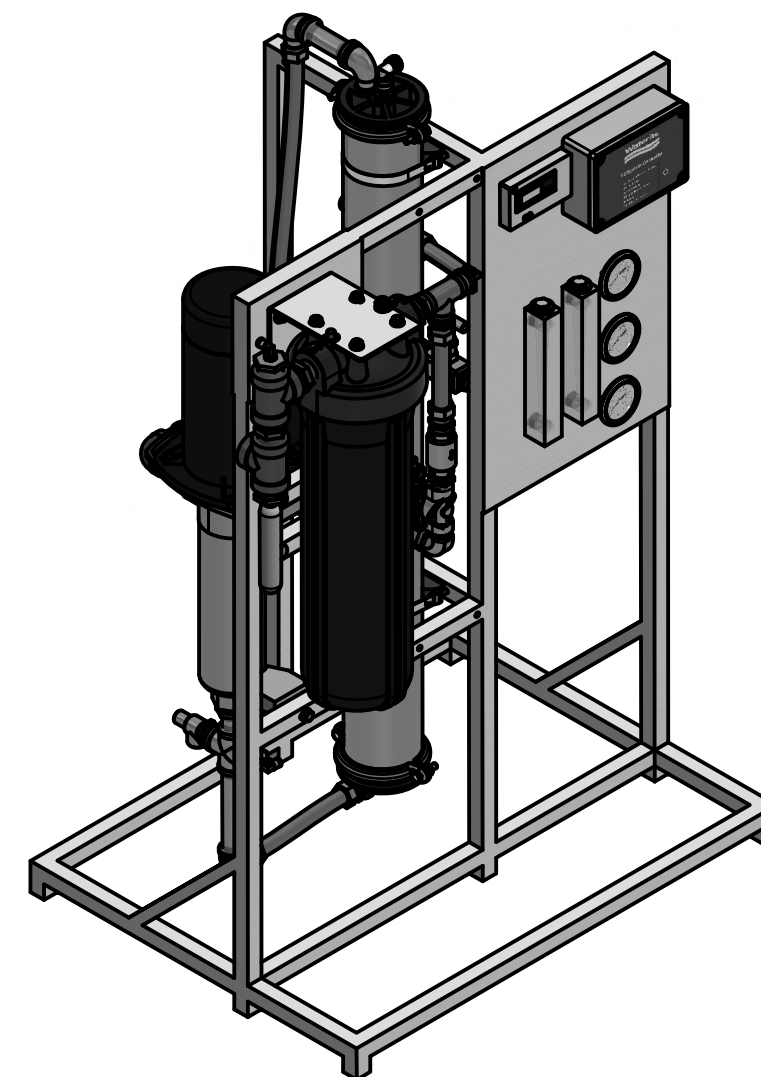

DRAWN MF	06/08/2021	WATERITE INC- A FRANKLIN COMPANY		
CHECKED		TITLE		
QA		REVERSE OSMOSIS SYSTEM		
MFG		2400		
APPROVED		SIZE	DWG NO	REV
		B	2400	4
		SCALE	1 / 10	SHEET 1 OF 18